

Pickit

Robot Vision Made Easy

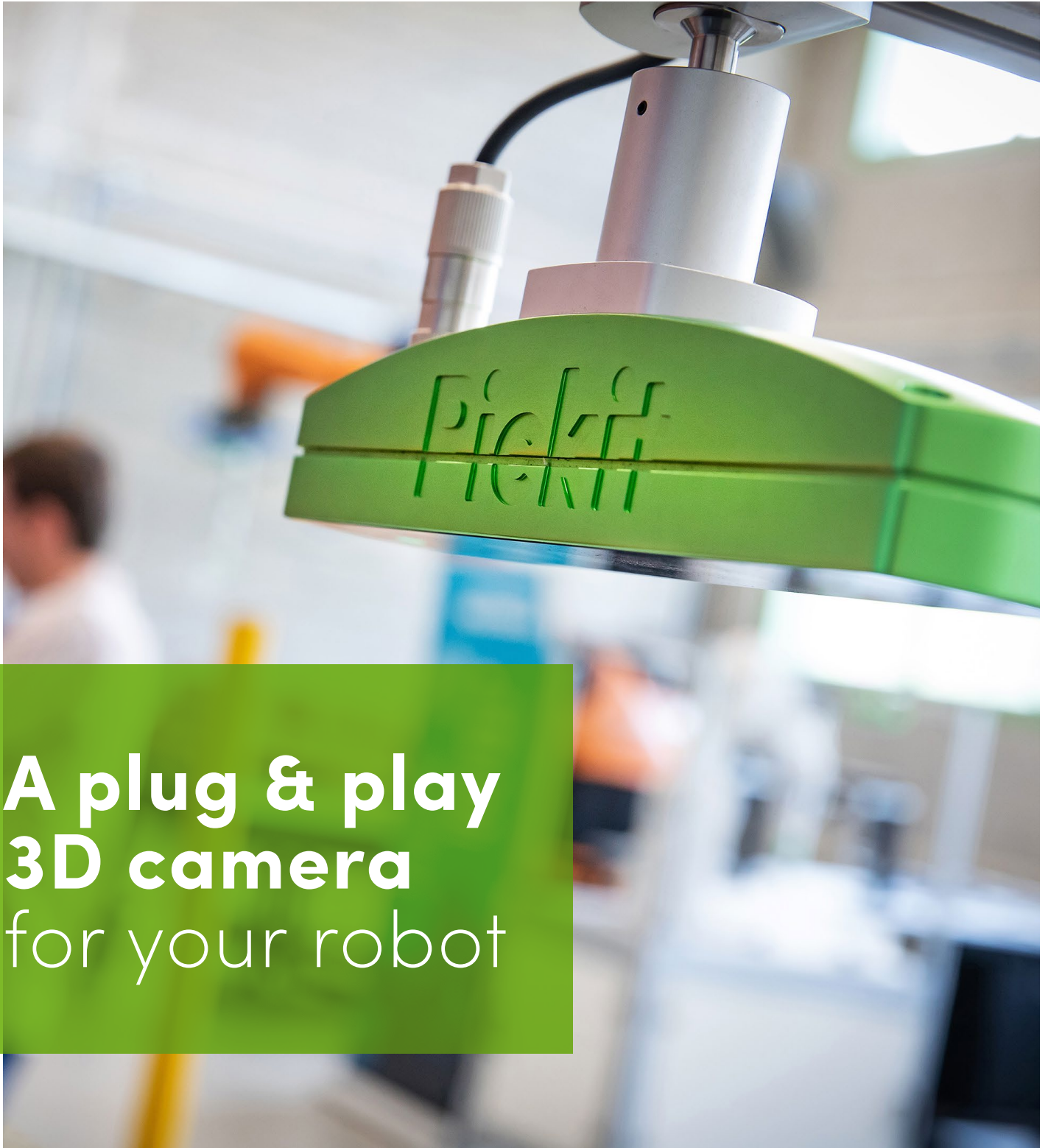

**A plug & play
3D camera
for your robot**

Automate any pick and place task

Manufacturers worldwide are doing their best to keep up with high standards and strong competition. Production needs to be bigger and better while **labor shortage** is rising. The solution to their struggles?

The automation of manufacturing processes with robots.

These processes involve the **picking and placing** of different kinds of parts at the beginning and end of the production line. This takes 40% of the labor force's working time. However, these tasks were traditionally hard and often impossible to automate.

Pickit makes this possible by making the robot smarter. The 3D camera and software **give the robot eyes** so it can see the objects in order to pick them.

“Bin picking is one of the biggest challenges in today's manufacturing and now I can say it's possible with Pickit.”

— Yann Danesin, Continental, France

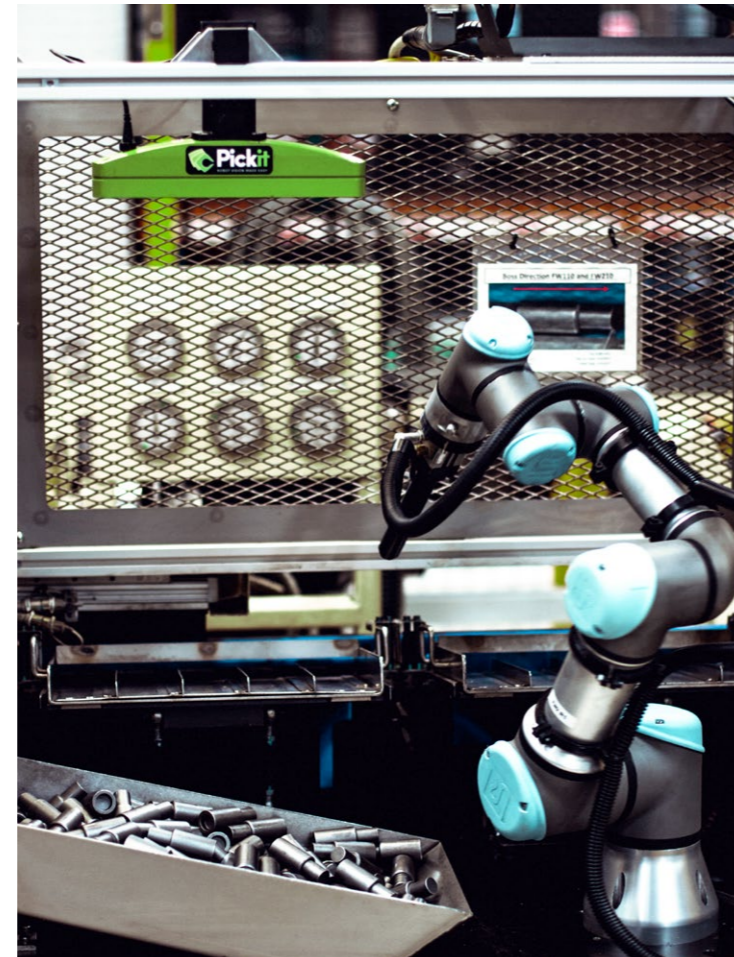

UR+ CERTIFIED

Setting up and running an application with Pickit on your Universal Robots robot is nearly effortless with the free Pickit **URcap**.

support.pickit3d.com/urcap



“Pickit adds an extra tool in our tool box. We can automate processes that we were not able to automate before.”

— Tom Sheehe, NEFF, USA

Increase the efficiency of your process



bin picking

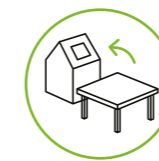

machine tending

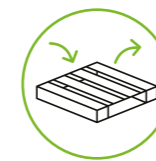

pallet unloading

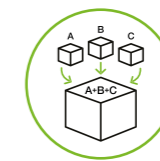

kitting and assembly

This is how it's done

1. Show an example part to the 3D camera
2. Tell Pickit where to look with our click and drag tool
3. Pickit will tell your robot where the best pickable part is

Pickit will show your robot where to pick parts and place them onto:

- a CNC Machine
- an assembly line
- a conveyor belt
- a welding station
- a working bench
- a tray
- a box
- a package
- a co-workers hand
- and much more...

Our artificial intelligence makes your robot smart

Our product:

- learns what your parts and tool look like,
- knows where your robot and bin are,
- predicts & prevents collisions with obstacles and other parts,
- decides the best part to pick next,
- and much more ...

“We used to finish 400 broomsticks with 6 people. Now we finish 1000 broomsticks with 3 people.”

— Roelof Talen, Talen Tools, The Netherlands



WE VALUE TIME AS MUCH AS YOU DO
A typical detection cycle takes **less than one second** and can find multiple parts in one cycle.

USE PICKIT WITH THE ROBOT OF YOUR CHOICE

FANUC

STÄUBLI

KUKA

YASKAWA

ABB

UNIVERSAL ROBOTS

Pickit

FRANKA EMIKA

AUBO

Hanwha

HYUNDAI ROBOTICS

NACHI

OMRON

TM

Now tell us about your application!

And we'll show you how we automate it: pickit3d.com/go

has been convinced since 2017

Set-up

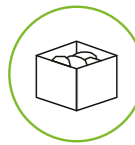

Bin picking application

Problem



Labor shortage

Solution



Universal Robots

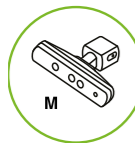

Pickit vision system

Result

- The operator manages two lines instead of one and has more time for value-adding tasks
- The risk of human error was eliminated



“Pickit was able to achieve our goal a lot easier than other solutions.”

- Jerry Reamer, Director Production Engineering at KYB

5 easy ways to benefit from Pickit



Automate with full flexibility

The Pickit software is designed to handle fast adaptations and many different products.

“This machine can handle any part. All you have to do is feed parts under the camera, and there’s your set-up.”

— Adam Wiltzie, Vanomatic, USA



Save installation and setup time

No need for vision experience or a single line of code.

“It’s an elegant solution that fit directly into our current production cell with very little modifications. It was very easy to install.”

— Mike Waddell, KYB, USA

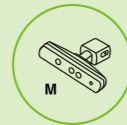

Get rid of bulky and space-taking fixtures

Keep things simple and your factory footprint low with this elegant solution.



Worry less with 24/7 reliability

Pickit delivers quality of work without breaks, vacations or turnover.



Cut costs at a fixed price

Pickit works out of the box, eliminating unexpected integration costs.

“If we have a robot running 24 hours a day 5 days a week, the ROI is probably close to 5 months”

— Doug Sanford, 21st Century Plastics, USA

Pickit supports you on your automation journey

Proof of concept

We want to show you we can solve your automation needs. We evaluate your case with our global partner network, so you know exactly what Pickit can do for you.

Online knowledge base

Pickit’s extensive online knowledge base contains more than 100 articles ranging from basic to advanced. Visit support.pickit3d.com for articles, training materials and webinars.

Built-in support

Pickit has a built-in snapshot tool. In a snapshot, the camera images and detection parameters of the last detection are stored. This allows us to give you remote support as if we were there.

Direct support

Did you run into an issue? Just contact us or one of our local partners and we’ll help you out.

Live and remote training

Do you want to discover all possibilities of our system? Don’t hesitate to request a training session – remote, or in our Belgium office.



“Pickit provides a plethora of information on their support page. You can email them and expect a response within a day.”

— Austin Shope, ONExia, USA

Find the best solution for your application



Pickit_{M-HD}

- Best in class camera
- Picks **small and medium sized objects**
- High accuracy

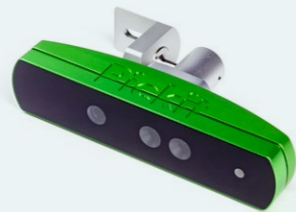

Pickit_M

- Highly versatile 3D camera
- Picks **medium sized objects**
- Fastest ROI in the market



Pickit_L

- Highly versatile 3D camera
- Picks **large sized objects**
- Pallet unloading



Thousands of objects
picked with Pickit

Contact us and
we'll demonstrate
how we pick your
objects.

pickit3d.com/go

Pickit M-HD facts

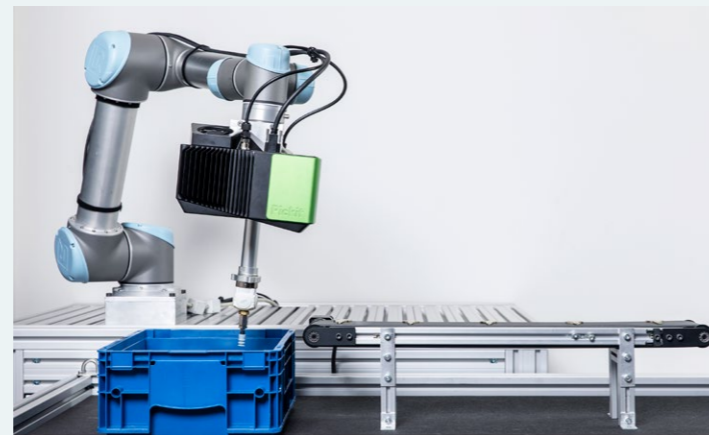
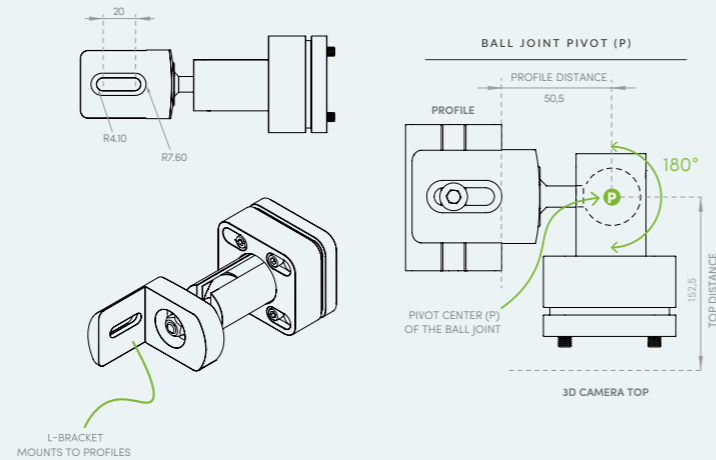
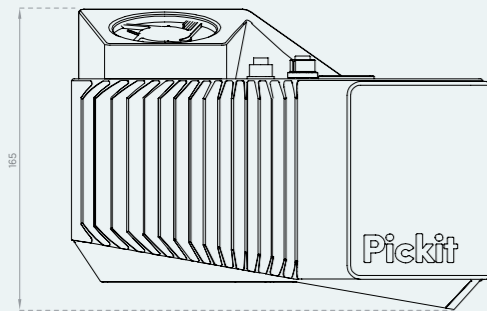
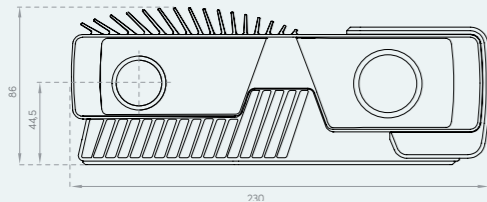

Minimum object size:
10 x 10 x 5 mm

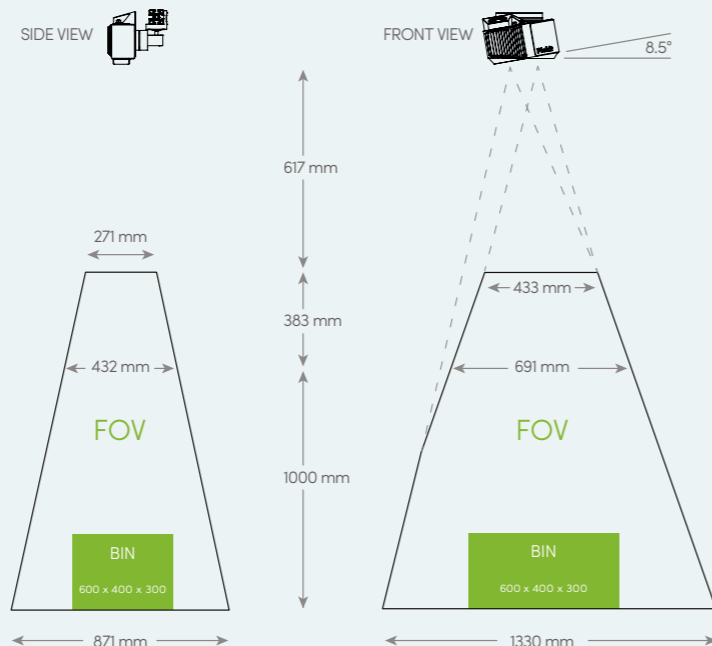
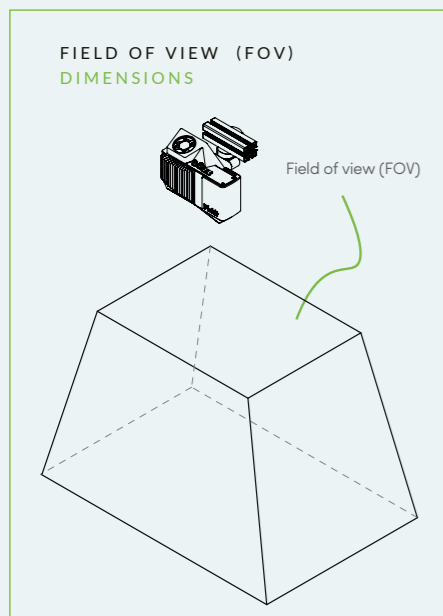

CAMERA TECHNICAL SPECIFICATIONS

3D measurement method	Structured light
Image processing speed	10 Hz (100ms snapshots)
3D Camera accuracy	0,1mm
3D Camera repeatability	< 1mm
3D camera weight	2 kg
3D camera connection to PC	M12-8 (USB) - USB3
PC connection to robot	TCP/IP over Ethernet
Power supply	M12-5 24VDC
Temperature	10°C to 40°C
IP rating	IP65
Vibrations	5G Sinus, 25G Shock
Conforms to	CE, CB, EN6950, FCC class A

CAMERA CABLE TECHNICAL SPECIFICATIONS

- 10m**
- Industrial M12 camera connector**
- High-Flex / Continuous-Flex**
- Type-U (R= 67,5mm - 5.000.000 times)
 - Type-S (R= 60mm - 1.000.000 times)
 - 90° Tick-Tock bending (R= 60mm - 1.000.000 times)

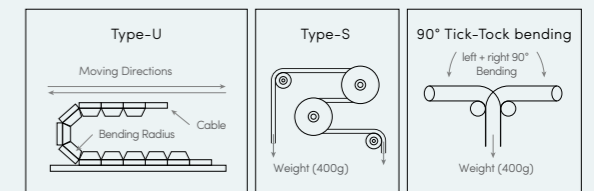

PROCESSOR

- Power consumption**
- While turned off: 25W
 - Booting: 115W
 - Idle: 70W
 - Heavy processing: 160W

- Technical specifications**
- Processor: 6 cores (12 threads) at 3.7 Ghz
 - 19 inch server: rack compatible (2U)
 - Temperature: -20°C to 70°C
 - Vibrations: Operating, 5 Grms, 5-500 Hz, 3 axes
 - IP rating: IP54
 - Power supply: 9-32V DC 160W
 - Humidity: -95% @ 40°C (non-condensing)
 - Weight: 11 kg



USE PICKIT WITH THE ROBOT OF YOUR CHOICE



Pickit

Pickit M facts

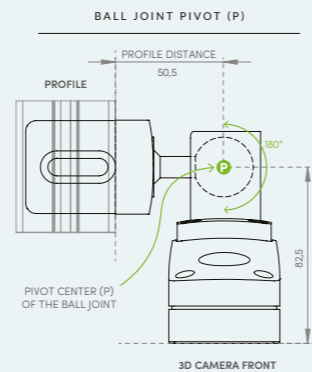
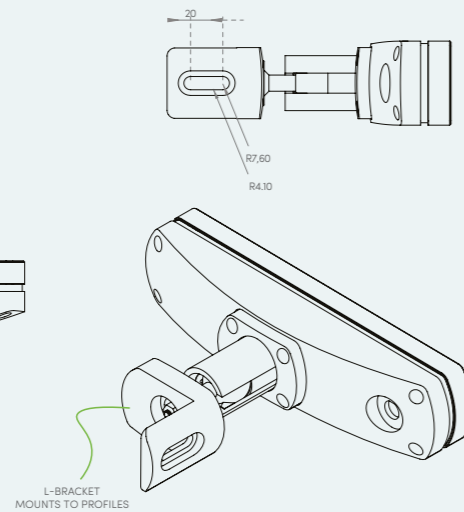
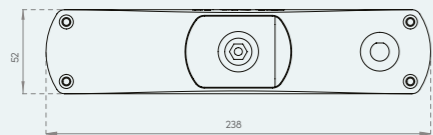
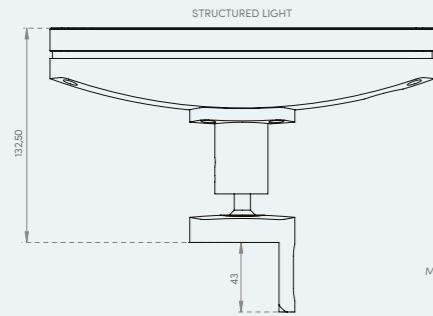

Minimum object size:
50 x 50 x 10 mm

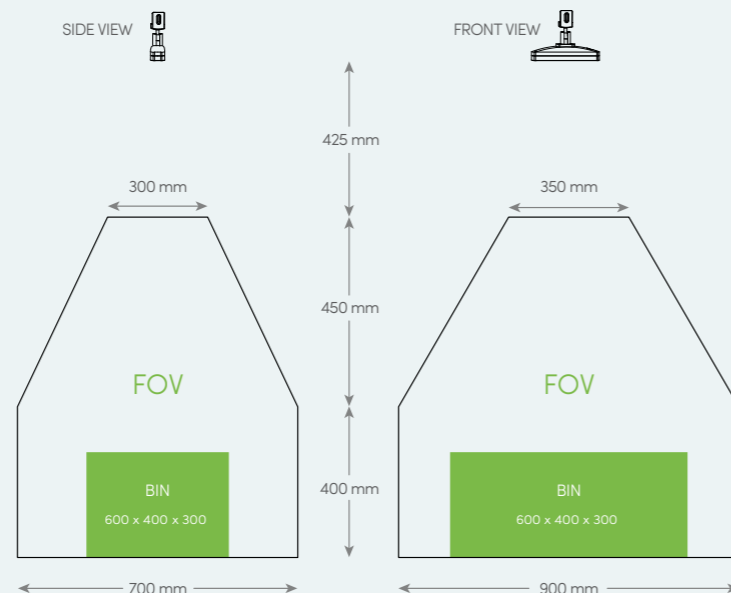
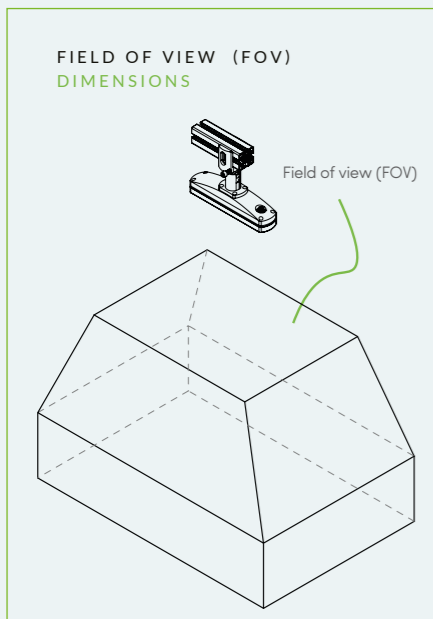

CAMERA TECHNICAL SPECIFICATIONS

3D measurement method	Structured light
Image processing speed	30 fps
3D Camera accuracy	< 3mm
3D Camera repeatability	< 1mm
3D camera weight	1030 g
3D camera connection to PC	M12 (USB) - USB3
PC connection to robot	TCP/IP over Ethernet
Power supply	USB3 5VDC
Temperature	5°C to 40°C
Humidity	-95% @ 40°C (non-condensing)
IP rating	IP55
Vibrations	Operating, 2 Grms, 5-500 Hz, 3 axes
Conforms to	CE, FCC

CAMERA CABLE TECHNICAL SPECIFICATIONS

- 10m**
- Industrial M12 camera connector**
- High-Flex / Continuous-Flex**
- Type-U (R= 67,5mm - 5.000.000 times)
 - Type-S (R= 60mm - 1.000.000 times)
 - 90° Tick-Tock bending (R= 60mm - 1.000.000 times)

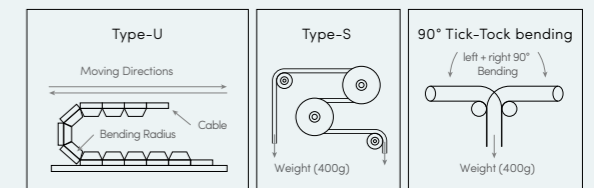

PROCESSOR

- Power consumption**
- While turned off: 25W
 - Booting: 100W
 - Idle: 60W
 - Heavy processing: 130W

- Technical specifications**
- Processor: 6 cores (12 threads) at 3.7 Ghz
 - 19 inch server: rack compatible (2U)
 - Temperature: -20°C to 70°C
 - Vibrations: Operating, 5 Grms, 5-500 Hz, 3 axes
 - IP rating: IP54
 - Power supply: 9-32V DC 160W
 - Humidity: -95% @ 40°C (non-condensing)
 - Weight: 11 kg



USE PICKIT WITH THE ROBOT OF YOUR CHOICE



Pickit L facts

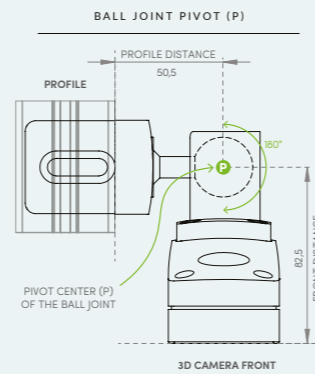
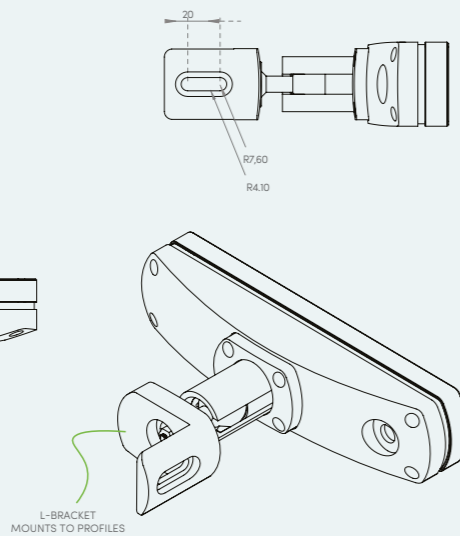
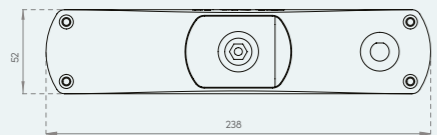
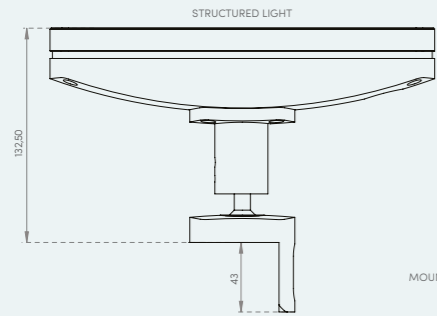

Minimum object size:
150 x 150 x 50 mm

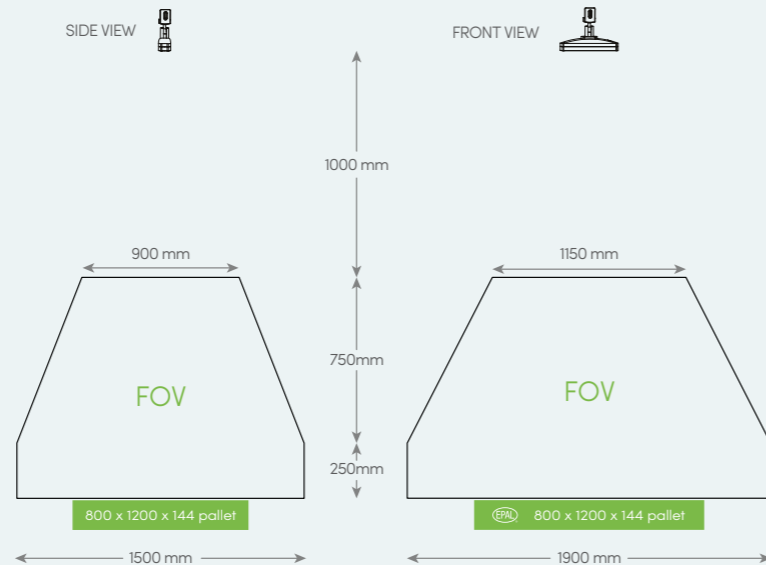
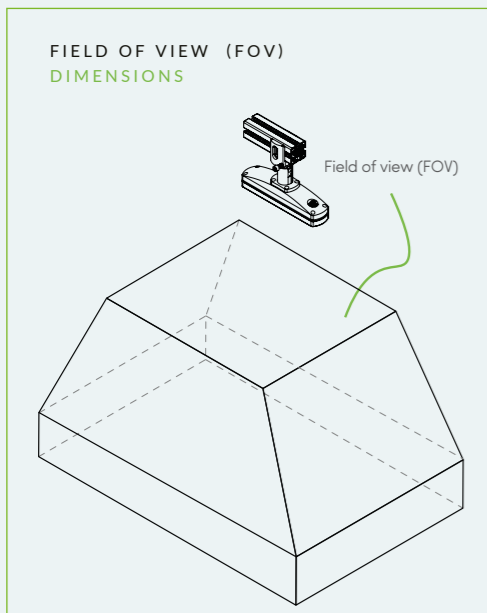

CAMERA TECHNICAL SPECIFICATIONS

Temperature	5°C to 40°C
Vibrations	Operating, 2 Grms, 5-500 Hz, 3 axes
IP rating	IP55
Power supply	USB3 5VDC
Humidity	-95% @ 40°C (non-condensing)
3D measurement method	Structured light
Image processing speed	30 fps
3D Camera accuracy	< 12mm
3D Camera repeatability	< 4mm
3D camera weight	1030 g
3D camera connection to PC	M12 (USB) - USB3
PC connection to robot	TCP/IP over Ethernet
Conforms to	CE, FCC

CAMERA CABLE TECHNICAL SPECIFICATIONS

- 10m**
- Industrial M12 camera connector**
- High-Flex / Continuous-Flex**
- Type-U (R= 67,5mm - 5.000.000 times)
 - Type-S (R= 60mm - 1.000.000 times)
 - 90° Tick-Tock bending (R= 60mm - 1.000.000 times)

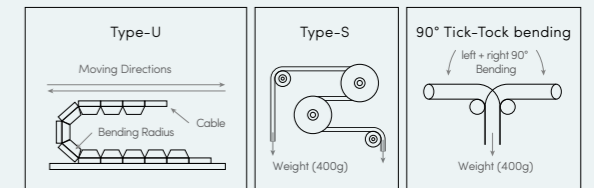

PROCESSOR

- Power consumption**
- While turned off: 25W
 - Booting: 100W
 - Idle: 60W
 - Heavy processing: 130W
- Technical specifications**
- Processor: 6 cores (12 threads) at 3.7 Ghz
 - 19 inch server: rack compatible (2U)
 - Temperature: -20°C to 70°C
 - Vibrations: Operating, 5 Grms, 5-500 Hz, 3 axes
 - IP rating: IP54
 - Power supply: 9-32V DC 160W
 - Humidity: -95% @ 40°C (non-condensing)
 - Weight: 11 kg



USE PICKIT WITH THE ROBOT OF YOUR CHOICE





Find us **all** **over the** **world**

Pickit has a global network with excellent partners. These trained Pickit experts distribute Pickit and provide first class local support.

Get in touch

We'll help you save time, lower costs and ensure a reliable output with a product that ensures the fastest ROI on the market.

Do you want to benefit from Pickit? **Contact us or one of our partners today.**

+32 16 624 882
sales@pickit3d.com

 @pickit3d  /pickit3d
 /pickit3d  @pickit3d
www.pickit3d.com

